

Stainless Tool Maker Vise

53342

VLS

Stainless Tool Maker Vise



Material :SUS440

Hardness:HRC45°~55°

Parallelism:within 0.003mm/100mm

Squareness:within 0.005mm/100mm

Features :

- ▶ Suitable for EDM, milling, and precision grinding work.

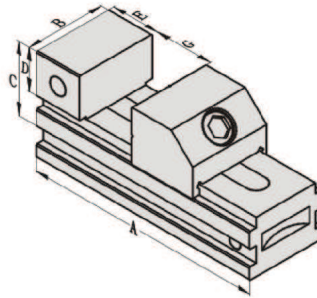

Unit:mm

Order No.	Model	A	B	C	D	E	G	N.W.
53342-01	VLS15	100	35	40	20	25	0~45	1.0kg
53342-02	VLS20	140	48	50	25	25	0~75	2.0kg
53342-03	VLS25	172	63	60	30	30	0~90	3.3kg
53342-04	VLS30	190	73	70	35	35	0~100	4.3kg
53342-05	VLS40	230	98	80	40	40	0~125	9.8kg

53346

VHS

Stainless Tool Maker Vise

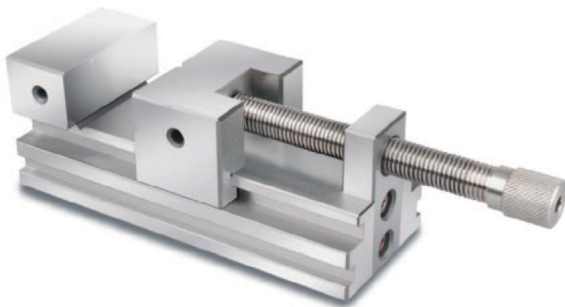

Material :SUS440

Hardness:HRC45°~55°

Parallelism:within 0.003mm/100mm

Squareness:within 0.005mm/100mm

Features :

- ▶ Suitable for EDM, milling, and precision grinding work.

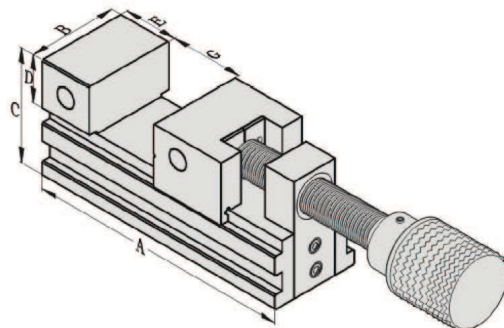

Unit:mm

Order No.	Model	A	B	C	D	E	G	N.W.
53346-01	VHS20	140	48	55	25	25	0~70	2.60kg
53346-02	VHS25	172	63	69	30	30	0~85	4.80kg
53346-03	VHS30	190	73	78	35	35	0~100	6.60kg
53346-04	VHS40	230	98	92	40	40	0~125	13.0kg