

**53185**

**WDV280**

**Stainless Precision Vise For EDM**

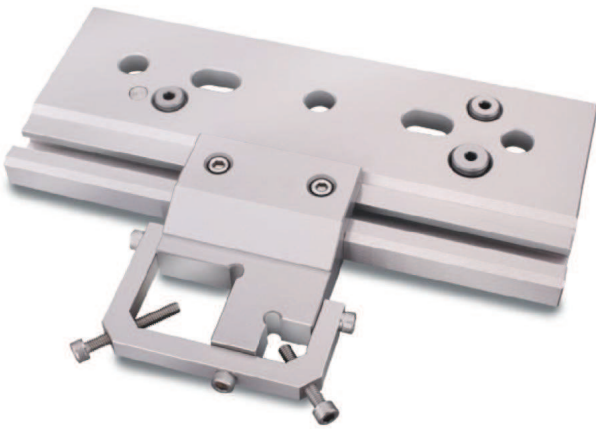

Leveling adjustment

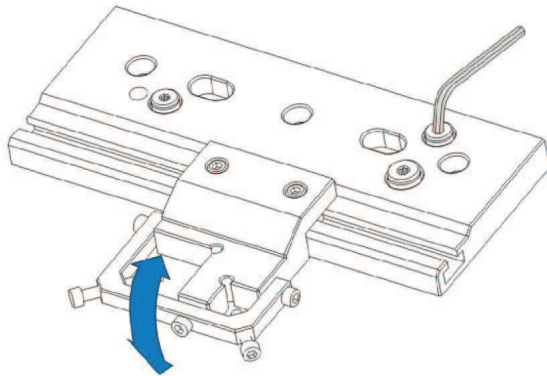

Leveling adjustment

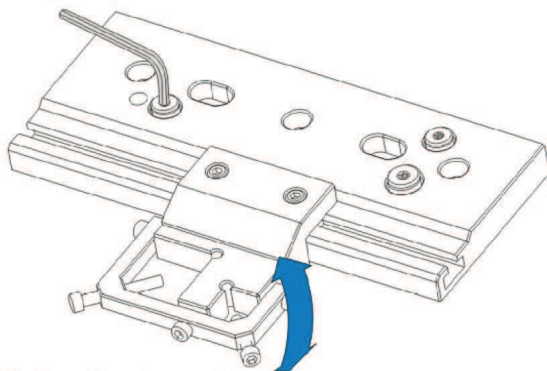

Parallel adjustment

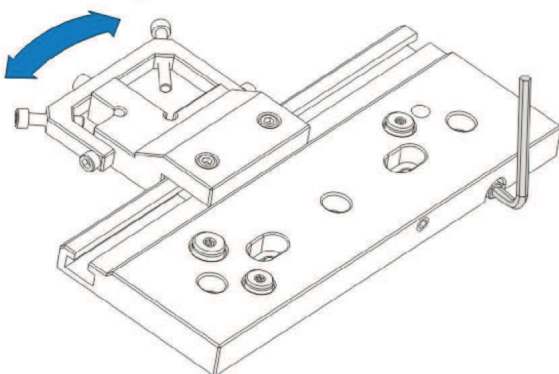

**Features :**

- ▶ Adopting high quality stainless steel (ASSAB STAVAX) with Sub-zero Treatment after Vacuum Heat Treatment, stable and distortion free.
- ▶ With 45° Jaw design, workpiece anti-floating when clamp.
- ▶ Adopting ball bearings and make 3-axis adjustment much more efficient.  
High water pressure resistance when clamping.
- ▶ Clamping range for round workpiece:  $\varnothing 3 \sim \varnothing 38$  mm
- ▶ In small V groove:  $\varnothing 3 \sim \varnothing 20$  mm
- ▶ In large V groove:  $\varnothing 10 \sim \varnothing 38$  mm
- ▶ Hardness: HRC45°~ 55°
- ▶ Parallelism: within 0.003/100mm
- ▶ Squareness: within 0.005/100mm

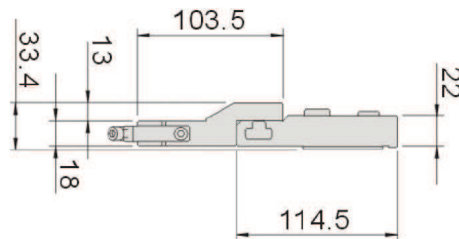
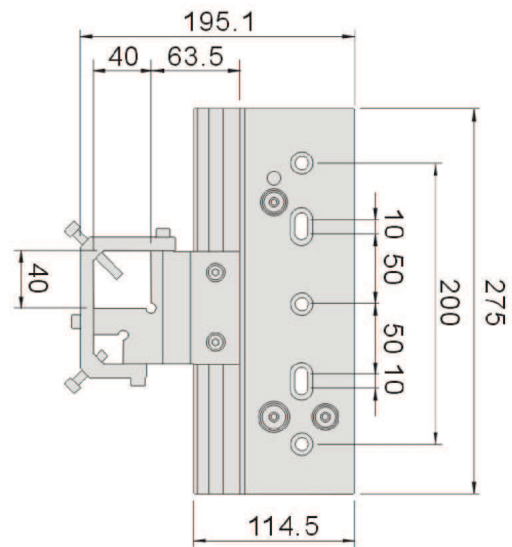

Unit:mm

Spec	Clamping range		N.W.
	Small V groove	Large V groove	
33.4x195.1x275	$\varnothing 3 \sim \varnothing 20$	$\varnothing 10 \sim \varnothing 38$	5.7kg

WIRE EDM EXTENSIONS CLAMP