

M × l Pitch	N Pitch	l	D1	R	T	B	TYPE	D	L 5mm increments
M4 × 12 P0.7	M4 P0.7	8 ~ 13	12	1.0	3	8	SGPW	8	25 ~ 70
			14					10	
M5 × 12 P0.8	M5 P0.8	10 ~ 15	17	1.5	5	10		13	30 ~ 75
M6 × 15 P1.0	M6 P1.0		23					16	40 ~ 100
M8 × 20 P1.25	M8 P1.25	16 ~ 21	27	2.0	13	16		20	60 ~ 120
			32					25	



Order Example

TYPE	D	L(LC)
SGPW	- D10	- L50

Alteration	Code	Spec.
	LC	Full length change D8 ~ 23 25 ≤ LC < L D16 ~ 25 (Lmin - 5) ≤ LC < L 0.5mm increments

Alteration	Code	Spec.
	BC	B dimension change 1mm increments 5 ≤ BC < B ⚠ M tapping depth is shortened by (B - BC)

- Use these stripper guide pins for die sets in which the punch plate is lifted up from the lower-die side.

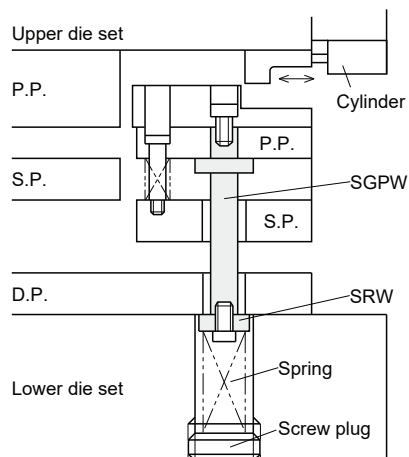

Intermittent cutting process for progressive die

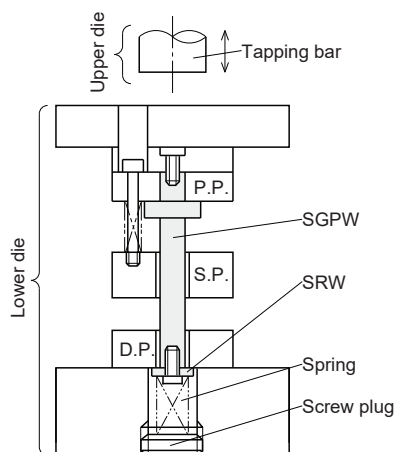

Movable lower die (tapping die)