



① Body



② Actuation Block



M-CVPL (Parting line mount type) ① only
M-CVP (External mount type) ① + ②

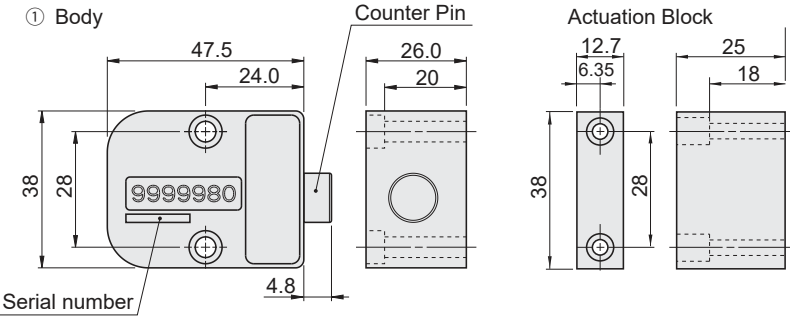

	M
①	Glass - filled nylon housing
②	Steel

Order Example

TYPE
M-CVPL ① only
M-CVP ① + ②

Mounting dimensions and method

M-CVPL (Parting line mount type)

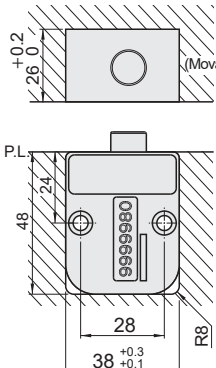

M-CVP (External mount type)

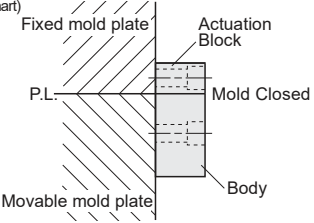

Stroke amount

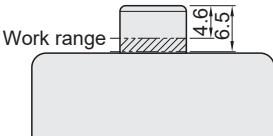

Stroke distance of the counter pin for counting function is set from 4.6mm to 6.5mm. When the stroke exceeds 6.5mm, the counter may be damaged.

Installation dimension shown in above figure is just for reference purpose

Features

- Counting is actuated mechanically, no miscount will occur if counter is installed correctly.
- Each counter has a different serial number that will be used to identify the counter with the mold.
- Counters are sold in random order.
- ID plate for tool identification is included. Apply the adhesive seal at the back of the ID plate to the front of the counter

Notes

- The Counter is non - resettable mechanical.
- For mold testing purposes, the 7-digit indicator does not start from 0 (a value of 9999980 will be shown)
- Due to the product structure, a part of the "5" count display is missing.

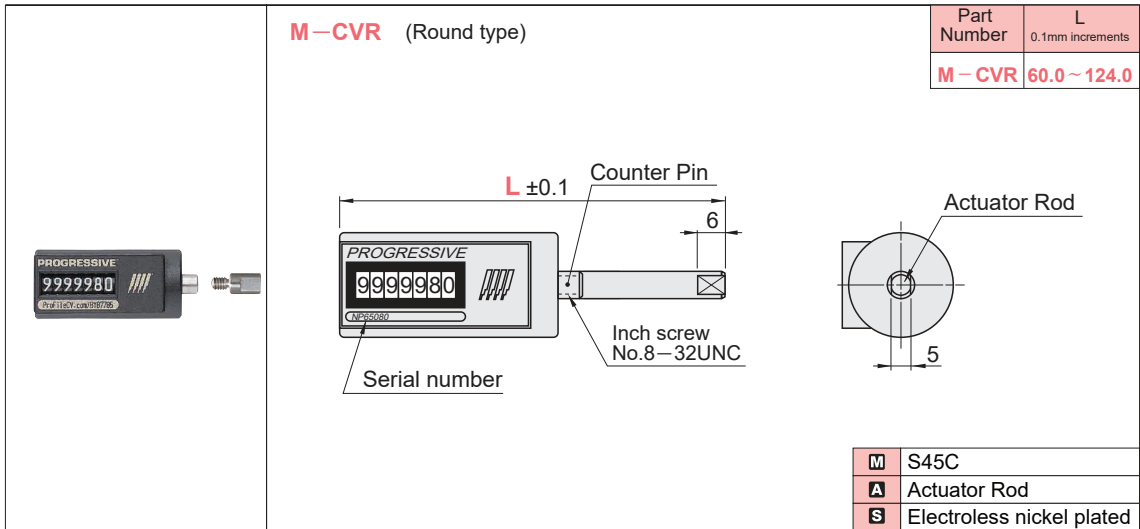

Order Example

TYPE	L
M-CVR	L100

Method of specifying the L dimension

L = Movable mold plate thickness T + actuator rod protrusion of 4.0mm

⚠ Specify taking into account the tolerance of the mold plate thickness T

⚠ The protruding part of the actuator rod is the stroke of the actuator rod. If the stroke is less than 3.75mm, the counter will not work. Conversely, if the stroke exceeds 4.25mm the counter may be damaged when the mold closes.

Mounting dimensions and method

M-CVR

- Bore the holes for the counter and actuator rod to the dimensions shown in the figure below, from the rear of the movable mold plate.
- Slot an opening for the display panel of the counter to the dimensions shown in the figure below.
- Ensure that the actuator rod protrudes 4.0mm above the parting line and decide L dimension depending on the mold plate thickness.
- Screw the actuator rod into the plunger and insert the counter from the rear of the mold plate.
- Retain the bottom of the counter with the support plate

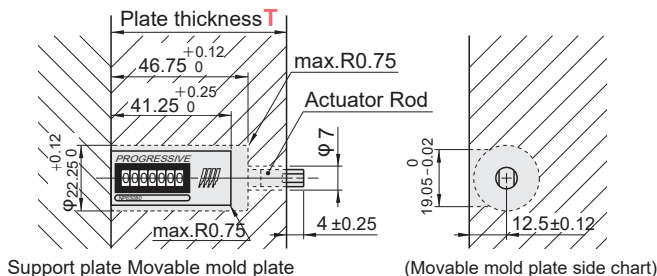

Features

- Counting is actuated mechanically, no miscount will occur if counter is installed correctly.
- Each counter has a different serial number that will be used to identify the counter with the mold.
- ⚠ Counters are sold in random order.

Notes

- ⚠ The Counter is non - resettable mechanical.
- ⚠ For mold testing purposes, the 7- digit indicator does not start from 0 (a value of 9999980 will be shown)
- ⚠ **M-CVR** Counter: Ensure that the actuator rod has a stroke of 4.0mm ± 0.25