

PLS ①-⑦ set
 PLM ①-⑦ set
 PLL ①-⑦ set

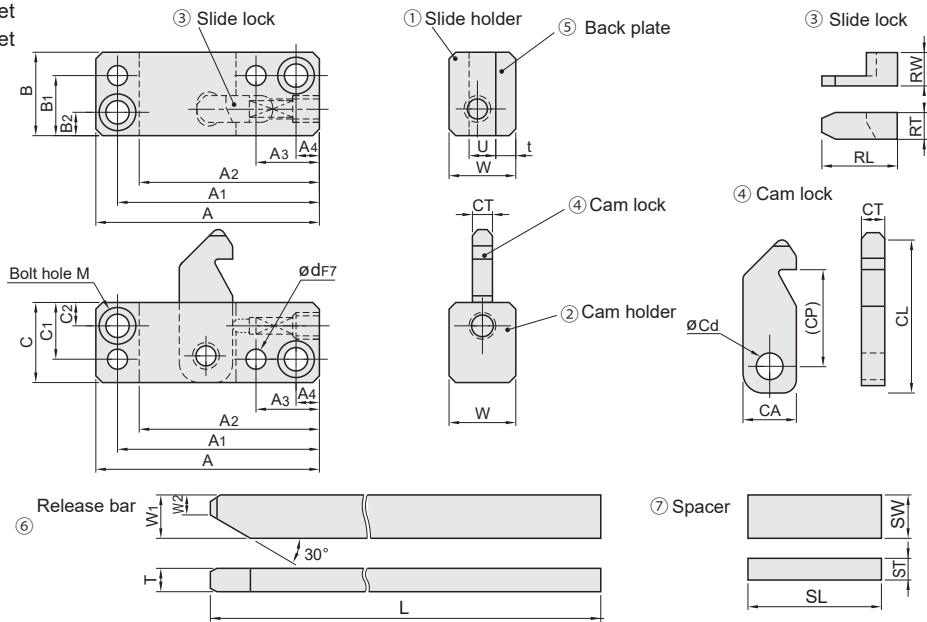

Item	① Slide holder	② Cam holder	③ Slide lock	④ Cam lock	⑤ Back plate	⑥ Release bar	⑦ Spacer
M	SKD61	SKD61	SKD11	SKD11	SK	S45C	S45C
H	50 ~ 55HRC	50 ~ 55HRC	58HRC ~	58HRC ~	50HRC ~	45HRC ~ Induction hardening	—

Part Number	① Slide holder • ② Cam holder														③ Slide lock			
	A	A1	A2	A3	A4	B	B1	B2	C	C1	C2	W	U	Bolt hole M	d	RL	RT	RW
PLS	68	61.5	55	19	7	26	19	7	24	17	7	20	8	For M6	ø6	18	7	11
PLM	88	79	70	24	9	38	29	9	30	21	9	30	12	For M8	ø8	20	9	16
PLL	104	93	82	27	11	48	37	11	38	27	11	45	20	For M10	ø10	24	12	26

④ Cam lock					⑤ t	⑥ Release bar				⑦ Spacer			Accessories			Part Number
CL	CP	CA	CT	Cd		W1	W2	T	L	SW	ST	SL	Bolt 4 pcs.	Dowel pin 4 pcs.	Spring 4 pcs.	
45	28	16	7.5	8	6	13	5.9	7	250	13	6.5	40	CB6 - 25	MSTM6 - 30	WHH6 - 15	PLS
64	41	20	10	10	7	16	8	10	300	16	8	50	CB8 - 35	MSTM8 - 40	WHH8 - 20	PLM
84	53.5	25	18	13	8	20	9.5	15.5	350	20	10.2	55	CB10 - 50	MSTM10 - 50	WHH8 - 20	PLL



Order Example

TYPE
PLM