

D1	BL	l	E	R	d	C	A	N Tap for pulling out	Mounting bolt size	Part Number	
										Type	D
16	32	6	6	2	2.3	0.8	10	M6	M5	PLBSP	10
20	37	8	7	2.5	2.8	1.0	11	M8	M6		13
25	46	10	9	3	3	1.0	14	M10	M8		16
30	51	10	9	3	3	1.0	14	M10	M8		20

**Features**

By using PLBS, polishing and R-chamfering of the hole at PL installation can be omitted.  
 The bushing mounting bolt can be mounted and removed from PL side, making maintenance easier.  
 Damage due to contact between the bushing mounting bolt and the tapered bolt (PLB) is prevented.

**How to Mount**

When creating and finishing a hole for this bushing, aim at  $D1 \pm 0.1$  tolerance for its diameter. (The depth of hole is a level of  $BL \pm 0.1$ )

Recommended finishing on the bushing's diameter(D1) is end milling

**Note**

When using PLBSP10, the diameter of counterbore for the bushing mounting bolt (A size) is the same as D size, so the resin sleeve (PLP) must be embedded approx. 3mm into the die plate so that the bushing mounting bolt's head does not come into contact with PLB (tapered bolt).

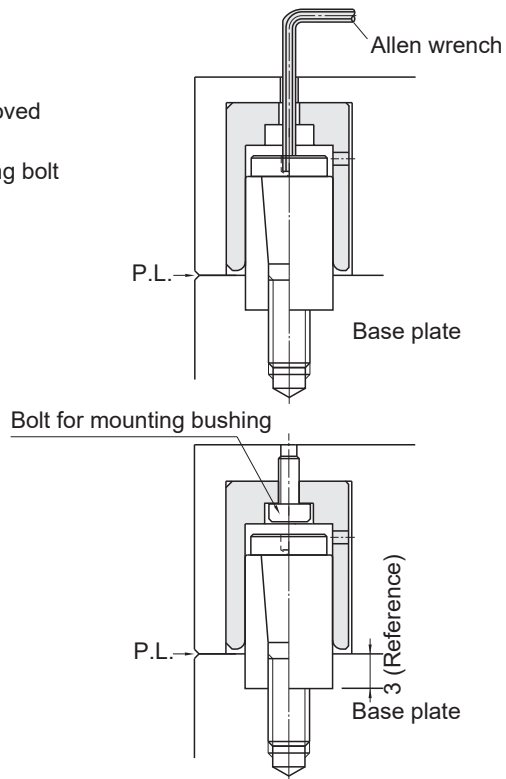

**Order Example**

TYPE
PLBSP10