

GH-301-AM

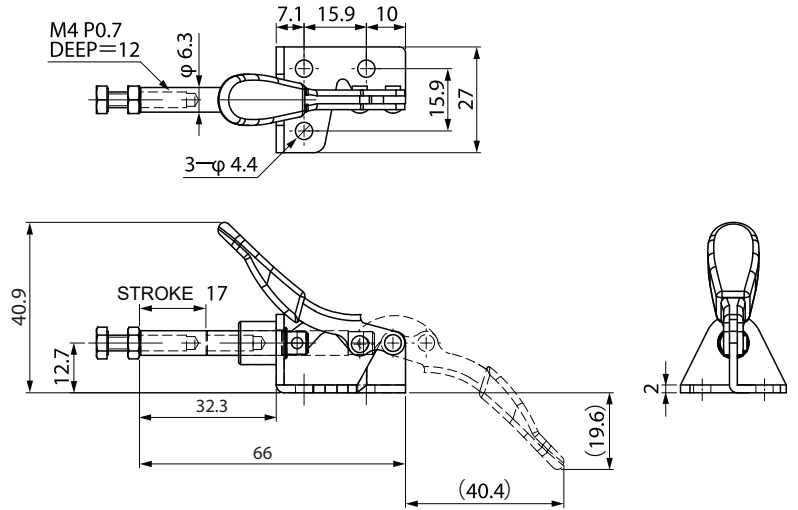

- ▶ HOLDING CAPACITY (夾持力): 45kg
- ▶ HANDLE OPENS (手柄開啟角度): 190°



GH-301-BM



- ▶ HOLDING CAPACITY (夾持力): 45kg
- ▶ HANDLE OPENS (手柄開啟角度): 190°

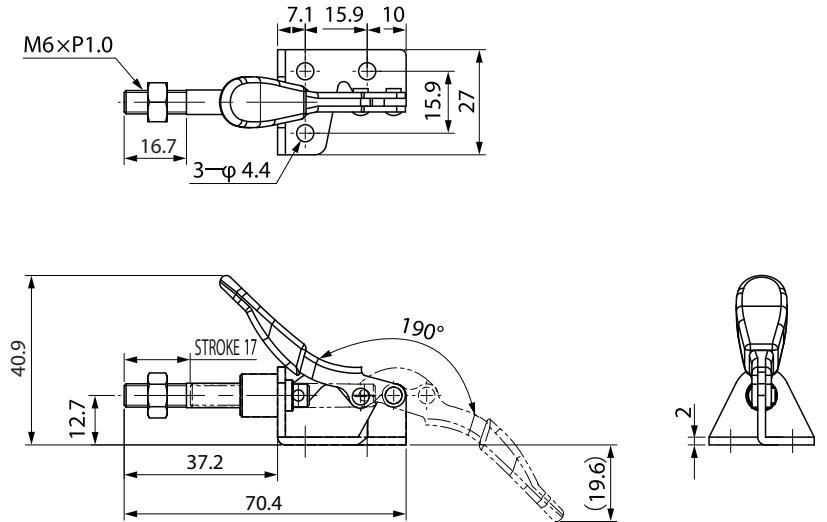

GH-36070



- ▶ WEIGHT (自重): 97g
- ▶ HOLDING CAPACITY (夾持力): 50kg
- ▶ SPINDLE SUPPLIED (壓頭螺絲型號): M5 × 16
- ▶ HANDLE OPENS (手柄開啟角度): 66°
- ▶ PLUNGER STROKE (行程): 10mm

