

Punch Former

51150

PFB

Punch Former

PUNCH FORMER



N.W.0.8kg

N.W. 7.6kg

**51150-01
PFB1**



N.W. 0.6kg

Features :

- ▶ PFB Punch Former have not just the same features of PFA but also with through hole design especially for longer pin or extended punches grinding.
- ▶ Adopting Arc attachment for dressing wheels in various shapes.
- ▶ The PFB1 attachment can also be applied to perform angular wheel dressing.

Main parameters:

Center height	80 ~ 81mm
Clamping dia. range of V-block	∅4 ~ 30mm
Travel of V-block	30mm
Indexer tooth q'ty & accuracy	24, 15° ± 10"
Clamping accuracy (50mm).....	0.005mm
Through hole dia.	∅ 30mm
Capable wheel size of dressing	∅ 200mm
Max. radius when dressing arc	
Convex	R48mm
Concave.....	R100mm

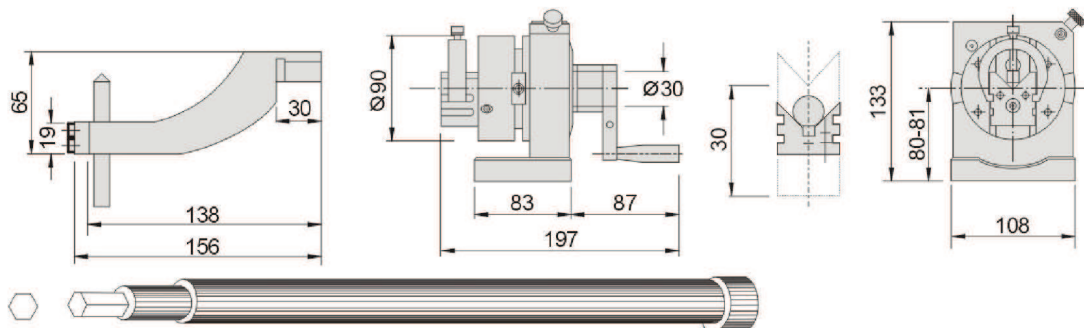

Punch forming applications

Grinding wheel dressing application

