

M—CVPL
Shot Counter

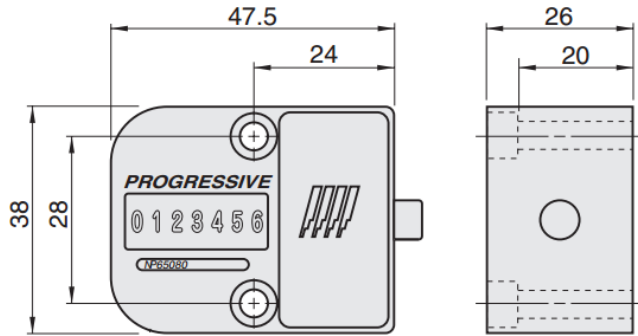

M Glass-filled nylon housing

M—CVR (Round type)

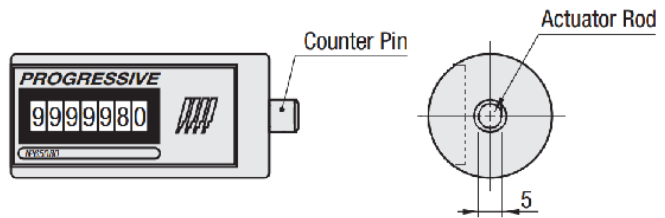

Mounting dimensions and method

M—CVPL (Parting line mount type)

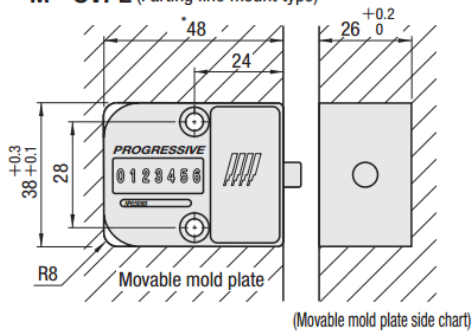

M—CVR

1. Bore the holes for the counter and actuator rod to the dimensions shown in the figure below, from the rear of the movable mold plate.
2. Slot an opening for the display panel of the counter to the dimensions shown in the figure below.
3. Ensure that the actuator rod protrudes 4.0mm above the parting line and decide L dimension depending on the mold plate thickness.
4. Screw the actuator rod into the plunger and insert the counter from the rear of the mold plate.
5. Retain the bottom of the counter with the support plate.

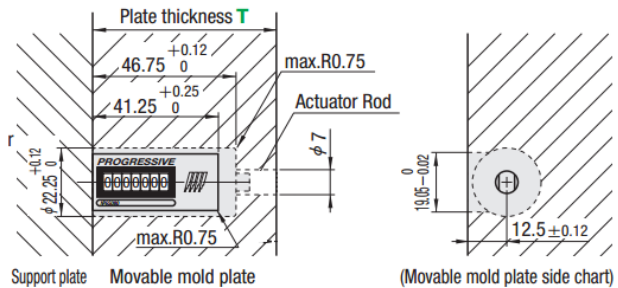

Type

M-CVPL

M-CVR