

# Magnetic Chuck

**54330**

FCD

Round Fine Pitch Permanent Magnetic Chuck



## Features :

- ▶ Suitable for surface grinding machine.
- ▶ Suitable for holding large workpieces.
- ▶ Overall sealed water resistance.
- ▶ High precision with strong magnetic force up to 13 kgf/cm<sup>2</sup>.

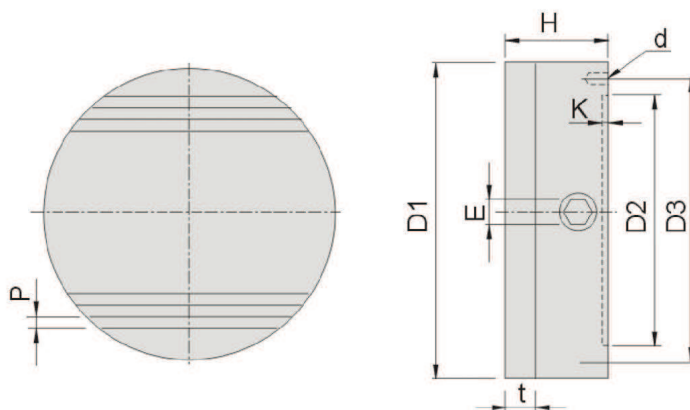

Unit:mm

Order No.	Model	D1	t	Pitch	D2	D3	K	d	E	H	N.W.
54330-100	FCD100	100	10	4 (1+3)	60	85	4	4-M6	8	52	3.15kg
54330-130	FCD130	130			90	115	4				4.9kg
54330-150	FCD150	150			110	132	4				6.7kg
54330-160	FCD160	160			120	140	4				7.7kg
54330-200	FCD200	200			160	180	5	4-M8			12.5kg
54330-250	FCD250	250			200	225	5				19.5kg
54330-300	FCD300	300			230	280	5				4-M10
54330-350	FCD350	350			230	311	5	39kg			
54330-405	FCD405	405			230	380	5	52kg			